

**Features**

- Single-chip CMOS construction
- Measurement range: 32.0 ~42.9°C (90°F ~ 109.9°F)
- Measurement accuracy:  $\pm 0.1^{\circ}\text{C}$  ( $\pm 0.2^{\circ}\text{F}$ )
- Resolution: 0.1°C (0.1°F)
- Single 1.5V battery operation
- Highest temperature hold
- Round off function
- Multi stable time selection: 4s/8s/16s/32s
- Automatic power off
- One ON/OFF switch input key
- Bonding option for °C and °F
- Display the last time measured temperature
- Alarm warning for fever
- Buzzer output: 6k/8kHz
- For various sensor application, change one layer only

**General Description**

The JA31107 is CMOS digital clinical thermometer IC for measuring body temperature from 32.0°C ~ 42.9°C (90°F ~ 109.9°F). It also provides stable alarm, fever alarm, automatic power off and the memory function of the last time measured

temperature. The chip provides multi stable time for various of thermister also. The other electronic components are LCD display, thermister, 1.5V battery, ON/OFF switch, buzzer, resistors and capacitors.

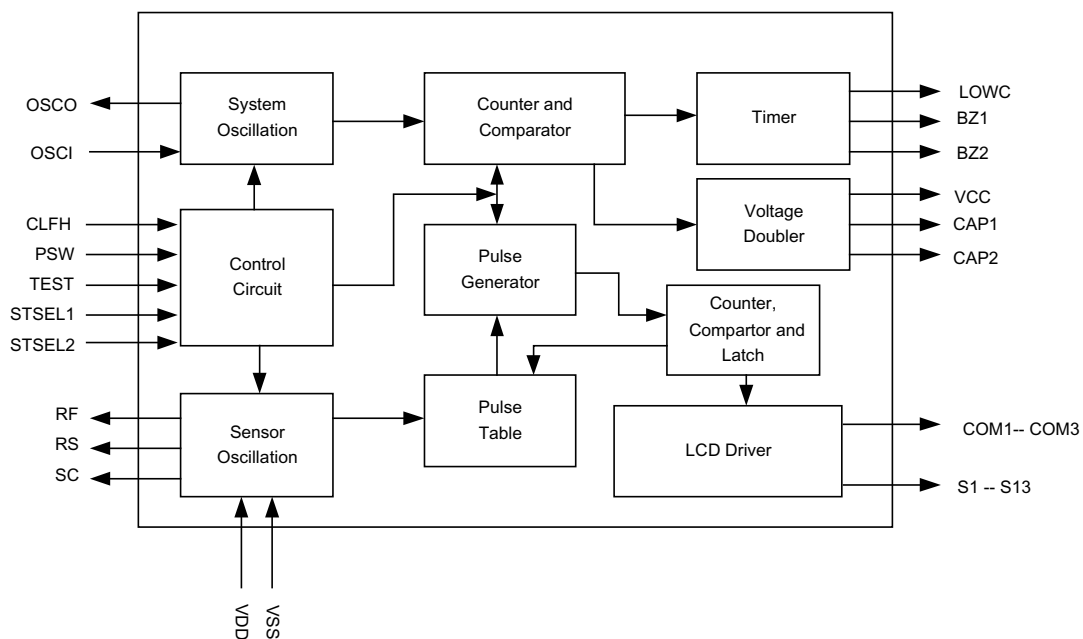
**Block Diagram**

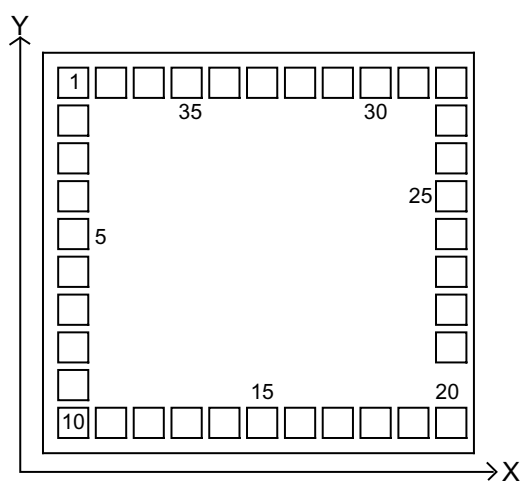
**Pad Assignment**

Note: The IC substrate should be connect to VSS

**Pad Coordinates**

Pad No.	Pad Name	X( $\mu$ m)	Y( $\mu$ m)	Pad No.	Pad Name	X( $\mu$ m)	Y( $\mu$ m)
1	S1	80	1105.3	20	SC	1180	80
2	S2	80	977.65	21	RF	1180	314.82
3	S3	80	867.65	22	RS	1180	424.82
4	S4	80	757.65	23	VDD	1180	534.82
5	S5	80	647.65	24	PSW	1180	644.82
6	S6	80	537.65	25	TEST	1180	754.82
7	S7	80	427.65	26	BZSEL	1180	864.82
8	S8	80	317.65	27	STSEL1	1180	974.82
9	S9	80	207.65	28	STSEL2	1180	1105.3
10	S10	80	80	29	ML	1070	1105.3
11	S11	190	80	30	FEVEL	960	1105.3
12	S12	300	80	31	OSCI	850	1105.3
13	S13	410	80	32	OSCO	740	1105.3
14	VCC	520	80	33	BZ1	630	1105.3
15	CAP1	630	80	34	BZ2	520	1105.3
16	CAP2	740	80	35	COM1	410	1105.3
17	CLFH	850	80	36	COM2	300	1105.3
18	LOWC	960	80	37	COM3	190	1105.3
19	VSS	1070	80	Chip size = 1400 $\mu$ m * 1300 $\mu$ m(X*Y)			

**Pad Description**

Pad No.	Pad Name	I/O	Function															
1 ~ 13	S1 ~ S13	O	LCD segment driver															
14	VCC	O	Generated 3V voltage															
15	CAP1	O	For positive voltage pumping, NMOS open drain output															
16	CAP2	O	For positive voltage pumping, inverter output															
17	CLFH	I	Selection of °C or °F CLFH= Open or VDD: °C CLFH= VSS: °F															
18	LOWC	I/O	For the supply voltage detector ; output?															
19	VSS	—	Negative power supply															
20	SC	I/O	Common point, NMOS open drain															
21	RF	O	Connect to reference resistor, PMOS open drain															
22	RS	O	Connect to sensor resistor, PMOS open drain															
23	VDD	—	Positive power supply															
24	PSW	I	Power ON/OFF input, toggle active															
25	TEST	I	For the test of production. TEST=Open or VDD: LCD display the highest value TEST=VSS: LCD display the real time value															
26	BZSEL	I	Buzzer output frequency selection BZSEL=Open or VDD: 8kHz BZSEL=VSS: 6kHz															
27 28	STSEL1 STSEL2	I	Stable time selection (STSEL1, STSEL2 is bonding option) <table border="1" data-bbox="539 1003 1093 1167"> <thead> <tr> <th>ST</th> <th>STSEL1</th> <th>STSEL2</th> </tr> </thead> <tbody> <tr> <td>4 sec</td> <td>VSS</td> <td>VDD or Open</td> </tr> <tr> <td>8 sec</td> <td>VDD or Open</td> <td>VSS</td> </tr> <tr> <td>16 sec</td> <td>VDD or Open</td> <td>VDD or Open</td> </tr> <tr> <td>32 sec</td> <td>VSS</td> <td>VSS</td> </tr> </tbody> </table>	ST	STSEL1	STSEL2	4 sec	VSS	VDD or Open	8 sec	VDD or Open	VSS	16 sec	VDD or Open	VDD or Open	32 sec	VSS	VSS
ST	STSEL1	STSEL2																
4 sec	VSS	VDD or Open																
8 sec	VDD or Open	VSS																
16 sec	VDD or Open	VDD or Open																
32 sec	VSS	VSS																
29	ML	I	Memory function option ML=Open or VDD: Without memory function ML=VSS: With memory function. The last measurement value will be displayed after power on.															
30	FEVEL	I	Fever function option FEVEL=Open or VDD: With fever function FEVEL=VSS: Without fever function															
31	OSCI	I	For system oscillator input															
32	OSCO	O	For system oscillator output															
33	BZ1	O	Buzzer output 1															
34	BZ2	O	Buzzer output 2															
35 ~ 37	COM1 ~ COM3	O	LCD common driver															

**Absolute Maximum Ratings**

Supply voltage..... 0V to 2.0V  
Input voltage..... VSS-0.5V to VDD+0.5V  
Operation Temperature..... -20°C to +75°C  
Storage Temperature..... -55°C to +125°C

\*Note: Stress above those listed under “Absolute Maximum Ratings” may cause permanent damage to the device. These are stress ratings only. Functional operation of this device at these or any other conditions above those indicated in the operational sections of this specification is not implied and exposure to absolute maximum rating conditions for extended periods may affect device reliability.

**Electrical Characteristics**

Symbol	Parameter	Test Conditions		Min.	Typ.	Max.	Unit
		V <sub>DD</sub>	Conditions				
V <sub>DD</sub>	Operating Voltage	—	—	1.3	1.5	1.65	V
I <sub>DD</sub>	Operating Current	1.5V	No Load	—	20	50	μA
I <sub>STB</sub>	Standby Current	1.5V	OSC OFF	—	—	1.0	μA
f <sub>OSC</sub>	Oscillation Frequency	1.5V	ROSC=1MΩ	25.6	32	38.4	KHz
R <sup>°C</sup>	Temperature Measurement Accuracy at Range 35°C ~ 39°C	—	VDD=1.3V ~1.5V	- 0.1	—	0.1	°C
R <sup>°F</sup>	Temperature Measurement Accuracy at Range 95°F ~ 102°F	—	VDD=1.3V ~1.5V	- 0.2	—	0.2	°F

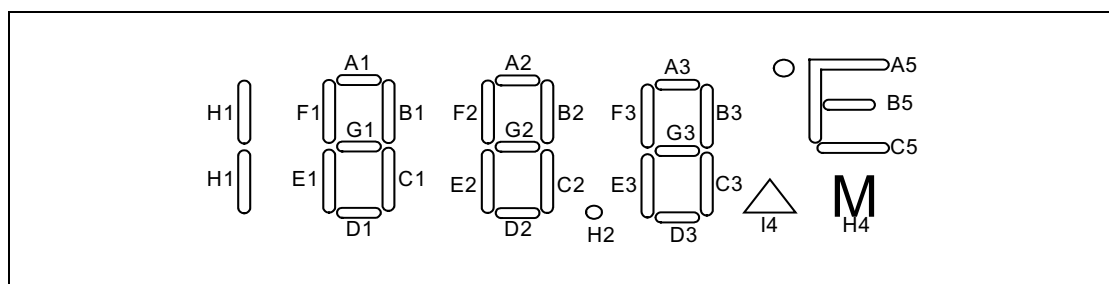
**LCD Electrode Pattern –**

Name	—	—	—	S1	S2	S3	S4	S5	S6	S7	S8	S9	S10	S11	S12	S13
COM1	COM1	—	—	F1	A1	B1	F2	A2	B2	F3	A3	B3				A5
COM2	—	COM2	—	E1	G1	C1	E2	G2	C2	E3	G3	C3				B5
COM3	—	—	COM3	H1	D1			D2	H2	H4	D3	I4				C5

Note: The LCD uses 3V and 1/3 duty, 1/2 bias

For one-digital decimal: COM1, COM2, COM3, S1, S2, S3, S4, S5, S6, S7, S8, S9, S13.

**Functional Description**

- Power SW: push PSW switch to power on or power off.
  - When power on: push the switch, a "BI" sound for 0.125sec will be generated.
- a. The LCD firstly all segments are on about 2sec.
  - b. After a. LCD shows the last-time temperature about 2sec. (If the memory function is optioned)
  - c. After b., LCD shows the self-test temperature (37.0±0.1°C) about 1 sec. The °C or °F mark will flash at the speed of 1Hz.
  - d. After c., LCD shows the higher measured temperature always, the °C(°F) mark will flash at the speed of 1Hz.
  - e. If the temperature < 32.0°C (or 90.0°F), the display show Lo °C (or Lo °F).
  - f. If the temperature ≥ 43.0 °C (or 109.9°F), The display show Hi °C (or Hi °F).
  - g. The LCD always show the higher temperature during the temperature measurement.
  - h. After power on, the measured temperature does not change within the stable time, the measurement will be over and the °C (°F) mark flash stop.
  - i. For JA31107 when measurement is over and if the temperature ≥ 37.8°C(100°F). In this case the buzzer alarms "BI-BI-BI--- BI-BI-BI---" for 10 sec, as follows:

BI --- BI --- BI ----- BI ---

BI: 0.125sec

---: 0.125sec

-----: 0.375sec

if the temperature < 37.80°C (100°F), the buzzer alarms “BI-BI-BI-BI-” for 10 sec, as follows:

BI --- BI---

BI: 0.5sec

---: 0.5sec

- j. It will automatically power off after measurement is stable and the system is still on more than 8 min 40sec(Fsys=32kHz)
  - k. When measurement is over and the beep sound is terminated, if the temperature rises within 8 min 40 sec, the measurement will start again, but the °C mark will not flash and the buzzer will not output also.
  - l. During bi sound is on 10 sec, the temperature is not measurement.
- When power off: the stand-by current  $\leq 1\mu\text{A}$ .
  - The frequency of buzzer is 6k(VSS) or 8kHz (Open or VDD) by pin option.
  - Measurement to 0.1 degree at °C.
  - Sensor use 503ET.
  - Reference resistor is the value sensor in 37.0 °C.
  - The low battery and “M” flag can not display when the temperature show Hi or Lo.
  - When battery voltage is low, the battery mark “▲” flashes at the speed of 1Hz and the measurement maybe not accurate. The low TEST pin connect to Vss, the measured temperature will be the actual temperature of voltage detect: 1.35V  $\pm 0.05\text{V}$ .
  - During the process of mass production, in order to adjust the reference resistance (RF), let the measured environment. The LCD can be up or down changed, not always show the higher one.
  - There are 4 kinds of stable time to be selected; 4 sec, 8 sec, 16 sec and 32 sec.

Time	STSEL1	STSEL2
4 sec	V <sub>SS</sub>	V <sub>DD</sub> / or open
8 sec	V <sub>DD</sub> /or open	V <sub>SS</sub>
16 sec	V <sub>DD</sub> /or open	V <sub>DD</sub> /or open
32 sec	V <sub>SS</sub>	V <sub>SS</sub>

Flow Chart

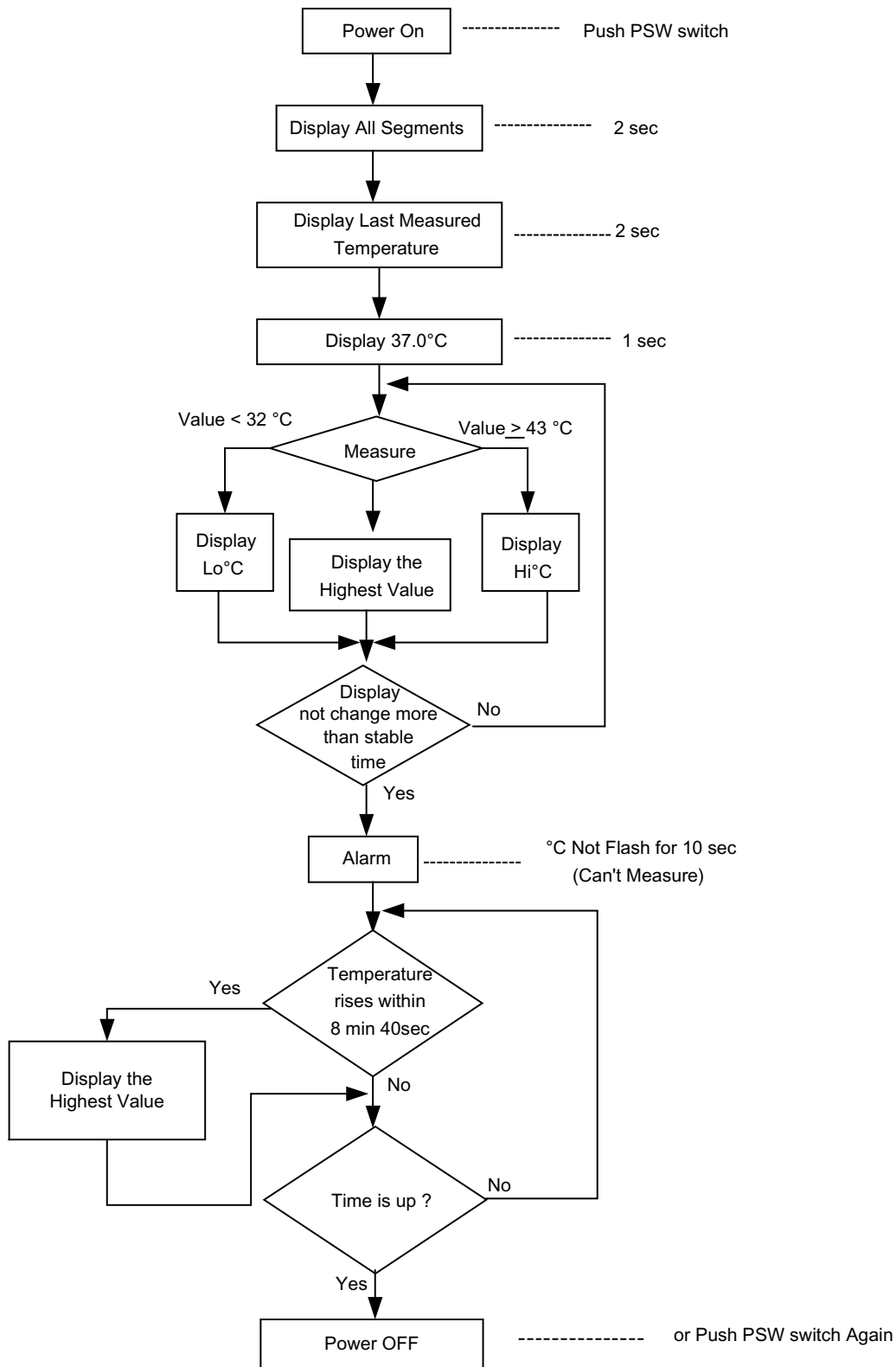

Application Circuit

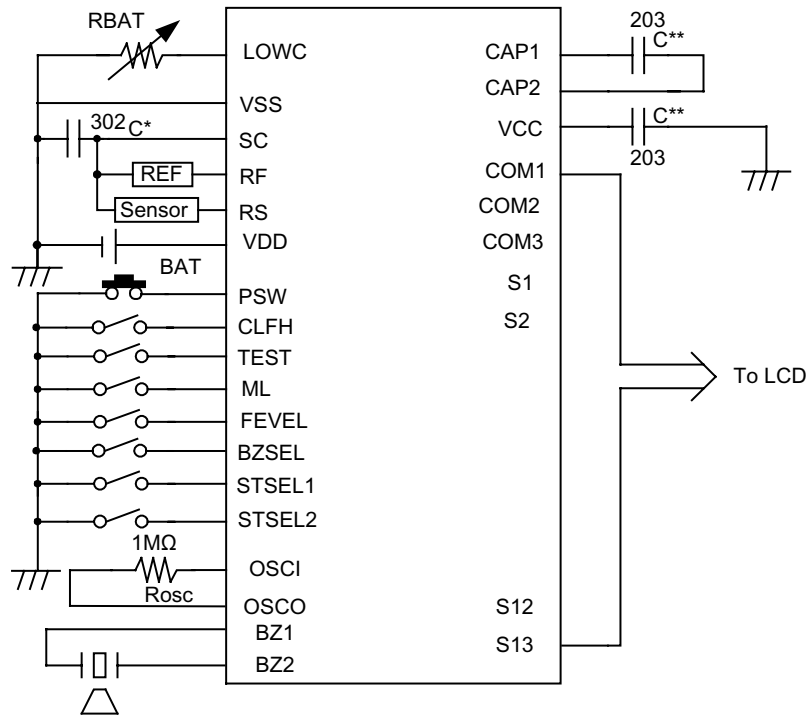

JA31107

Note:

REF=30.01kΩ

C\* = 272~302

C\*\* = 103~104

R<sub>BAT</sub> = 300k~330k for

1.35V ±0.05V.